

### AA SERIES ▀ LONG LIFE UP TO 10000 HOURS

#### KEY FEATURES



- HYBRID CONDUCTIVE POLYMER • SMD type
- Endurance: 105°C ▀ up to 10000 hours
- Low ESR and high ripple current
- Vibration Proof (VP) version (up to 30g) available
- AEC-Q200 version available



#### SPECIFICATIONS

Items		Performance Characteristics
Operating Temperature Range		-55 ~ +105°C
Rated Voltage Range	$V_R$	16 ~ 200V DC
Surge Voltage	$V_S$	( $V_R \leq 100V$ ): $V_S = 1.25 \cdot V_R$ ( $V_R \geq 200V$ ): $V_S = 1.15 \cdot V_R$
Capacitance Range	$C_R$	10 ~ 1500 $\mu$ F
Cap. Tolerance	$\Delta C$	$\pm 20\%$ (120Hz ▀ 20°C)
Leakage Current (20°C ▀ $V_R$ applied)	$I_{LEAK}$	Not to exceed the values shown in standard ratings After 2 minutes
Dissipation Factor % (20°C ▀ 120Hz)	$\tan \delta$	Not to exceed the values shown in standard ratings
Equivalent Series Resistance (20°C ▀ 100kHz)	ESR	Not to exceed the values shown in standard ratings

Lifetime Test			
Endurance 105°C ( $V_R$ & $I_R$ applied)	Test	<b>10000 hours</b>	$\leq 100V$
		<b>5000 hours</b>	$> 100V$
	$\Delta C/C_R$	Within $\pm 30\%$ of the initial value	
	$\tan \delta$	Less than 200% of the specified value	
	ESR	Less than 200% of the specified value	
	$I_{Leak}$	Less than the specified value	

#### DIMENSIONS STANDARD PACKAGE ▀ All dimensions in mm

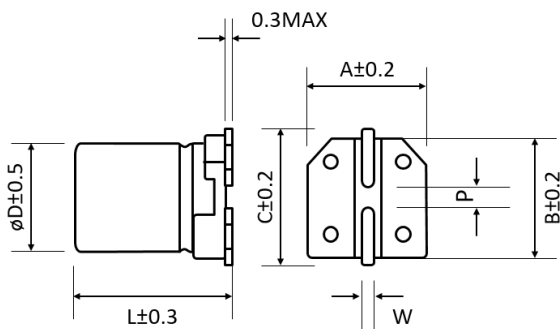

$\phi D$	L	A	B	C	W	P $\pm 0.2$
5	5.8	5.3	5.3	5.9	0.5 to 0.8	1.4
6.3	5.8	6.6	6.6	7.2	0.5 to 0.8	2.2
6.3	7.7	6.6	6.6	7.2	0.5 to 0.8	2.2
8	10.5	8.3	8.3	9.0	0.7 to 1.1	3.1
8	11.7	8.3	8.3	9.0	0.7 to 1.1	3.1
10	10.5	10.3	10.3	11.0	0.7 to 1.1	4.5
10	12.4	10.3	10.3	11.0	0.7 to 1.1	4.5
10	16.5	10.3	10.3	11.0	0.7 to 1.1	4.5

### DIMENSIONS VP PACKAGE (VIBRATION PROOF) ▪ All dimensions in mm

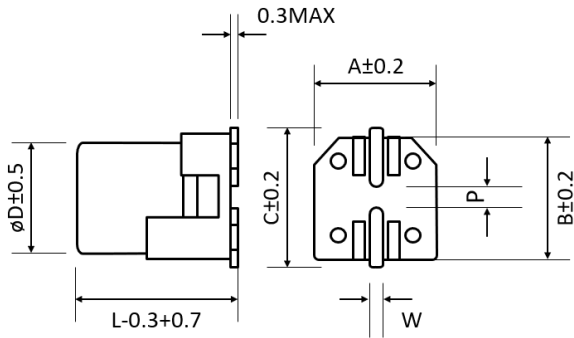

ø D	L	A	B	C	W	P±0.2
6.3	5.8	6.6	6.6	7.3	0.5 to 0.8	2.2
6.3	7.7	6.6	6.6	7.3	0.5 to 0.8	2.2
8	10.5	8.3	8.3	9.0	0.7 to 1.1	3.1
8	11.7	8.3	8.3	9.0	0.7 to 1.1	3.1
10	10.5	10.5	10.5	11.2	0.7 to 1.1	4.5
10	12.4	10.5	10.5	11.2	0.7 to 1.1	4.5
10	16.5	10.5	10.5	11.2	0.7 to 1.1	4.5

### STANDARD RATINGS

Part number shows blister tape on paper reel

V <sub>R</sub> (V)			C <sub>R</sub> (µF)	ø D (mm)	L (mm)	I <sub>LEAK</sub> (µA, 2min)	tanδ +20°C ▪ 120Hz (%)	Max. ESR +20°C ▪ 100kHz (mΩ)	I <sub>R</sub> ▪ Max. Ripple Cur- rent +105°C ▪ 100kHz (mA rms)	CapXon Part Number
	Standard	Vibration-proof								
16	•	•	100	6.3	5.8	16.0	16	50	1300	AA101M016E058PTR □□
	•	•	120	6.3	5.8	19.2	16	50	1300	AA121M016E058PTR □□
	•	•	150	6.3	5.8	24.0	16	50	1300	AA151M016E058PTR □□
	•	•	220	6.3	7.7	35.2	16	30	2000	AA221M016E077PTR □□
	•	•	270	6.3	7.7	43.2	16	30	2000	AA271M016E077PTR □□
	•	•	330	10	10.5	52.8	16	20	2500	AA331M016G105PTR □□
	•	•	470	8	10.5	75.2	16	27	2300	AA471M016F105PTR □□
	•	•	470	10	10.5	75.2	16	20	2500	AA471M016G105PTR □□
	•	•	560	8	11.7	89.6	16	23	2400	AA561M016F117PTR □□
	•	•	560	10	10.5	89.6	16	20	2500	AA561M016G105PTR □□
	•	•	820	10	12.4	131.2	16	16	2800	AA821M016G124PTR □□
25	•	•	1500	10	16.5	240.0	16	11	5000	AA152M016G165PTR □□
	•	•	33	5	5.8	8.3	14	80	900	AA330M025C058PTR □□
	•	•	56	6.3	5.8	14.0	14	50	1300	AA560M025E058PTR □□
	•	•	100	6.3	7.7	25.0	14	30	2000	AA101M025E077PTR □□
	•	•	220	8	10.5	55.0	14	27	2300	AA221M025F105PTR □□
	•	•	270	8	11.7	67.5	14	25	2400	AA271M025F117PTR □□
	•	•	330	10	10.5	82.5	14	20	2500	AA331M025G105PTR □□
	•	•	470	10	12.4	117.5	14	16	2800	AA471M025G124PTR □□
35	•	•	560	10	16.5	140.0	14	11	5000	AA561M025G165PTR □□
	•	•	22	5	5.8	7.7	12	100	900	AA220M035C058PTR □□
	•	•	27	6.3	5.8	9.5	12	60	1300	AA270M035E058PTR □□
	•	•	47	6.3	5.8	16.5	12	60	1300	AA470M035E058PTR □□
	•	•	68	6.3	7.7	23.8	12	35	2000	AA680M035E077PTR □□
	•	•	100	8	10.5	35.0	12	27	2300	AA101M035F105PTR □□
	•	•	150	8	10.5	52.5	12	27	2300	AA151M035F105PTR □□
	•	•	180	8	11.7	63.0	12	25	2400	AA181M035F117PTR □□
	•	•	270	10	10.5	94.5	12	20	2500	AA271M035G105PTR □□
	•	•	330	10	12.4	115.5	12	17	2800	AA331M035G124PTR □□
•	•	470	10	16.5	164.5	12	11	5000	AA471M035G165PTR □□	

□ see description at end of standard ratings

## STANDARD RATINGS

Part number shows blister tape on paper reel

$V_R$ (V)	Standard	Vibration-proof	$C_R$ ( $\mu F$ )	$\phi D$ (mm)	L (mm)	$I_{LEAK}$ ( $\mu A$ , 2min)	$\tan\delta$ +20°C • 120Hz (%)	Max. ESR +20°C • 100kHz (m $\Omega$ )	$I_R$ • Max. Ripple Cur- rent +105°C • 100kHz (mA rms)	CapXon Part Number
50	•		10	5	5.8	5.0	10	120	750	AA100M050C058PTR <input type="checkbox"/> <input type="checkbox"/>
	•	•	22	6.3	5.8	11.0	10	80	1100	AA220M050E058PTR <input type="checkbox"/> <input type="checkbox"/>
	•	•	33	6.3	7.7	16.5	10	40	1600	AA330M050E077PTR <input type="checkbox"/> <input type="checkbox"/>
	•	•	56	10	10.5	28.0	10	28	2000	AA680M050F105PTR <input type="checkbox"/> <input type="checkbox"/>
	•	•	68	8	10.5	34.0	10	30	1800	AA820M050F117PTR <input type="checkbox"/> <input type="checkbox"/>
	•	•	82	8	11.7	41.0	10	28	1880	AA680M050G105PTR <input type="checkbox"/> <input type="checkbox"/>
	•	•	100	10	10.5	50.0	10	28	2000	AA101M050G105PTR <input type="checkbox"/> <input type="checkbox"/>
	•	•	120	10	12.4	60.0	10	25	2200	AA121M050G124PTR <input type="checkbox"/> <input type="checkbox"/>
63	•	•	10	6.3	5.8	6.3	8	120	1000	AA100M063E058PTR <input type="checkbox"/> <input type="checkbox"/>
	•	•	22	6.3	7.7	13.9	8	80	1500	AA220M063E077PTR <input type="checkbox"/> <input type="checkbox"/>
	•	•	33	8	10.5	20.8	8	40	1700	AA330M063F105PTR <input type="checkbox"/> <input type="checkbox"/>
	•	•	47	8	10.5	29.6	8	40	1700	AA470M063F105PTR <input type="checkbox"/> <input type="checkbox"/>
	•	•	47	8	11.7	29.6	8	38	1750	AA470M063F117PTR <input type="checkbox"/> <input type="checkbox"/>
	•	•	56	10	10.5	35.3	8	30	1800	AA560M063G105PTR <input type="checkbox"/> <input type="checkbox"/>
	•	•	68	10	10.5	42.8	8	30	1800	AA680M063G105PTR <input type="checkbox"/> <input type="checkbox"/>
	•	•	82	10	12.4	51.7	8	22	2100	AA820M063G124PTR <input type="checkbox"/> <input type="checkbox"/>
80	•	•	150	10	16.5	94.5	8	15	4350	AA151M063G165PTR <input type="checkbox"/> <input type="checkbox"/>
	•	•	22	8	10.5	17.6	8	45	1550	AA220M080F105PTR <input type="checkbox"/> <input type="checkbox"/>
	•	•	27	8	11.7	21.6	8	43	1600	AA270M080F117PTR <input type="checkbox"/> <input type="checkbox"/>
	•	•	33	10	10.5	26.4	8	36	1700	AA330M080G105PTR <input type="checkbox"/> <input type="checkbox"/>
	•	•	47	10	10.5	37.6	8	36	1700	AA470M080G105PTR <input type="checkbox"/> <input type="checkbox"/>
100	•	•	56	10	12.4	44.8	8	32	1800	AA560M080G124PTR <input type="checkbox"/> <input type="checkbox"/>
	•	•	22	8	10.5	22.0	8	55	1400	AA220M100F105PTR <input type="checkbox"/> <input type="checkbox"/>
	•	•	22	8	11.7	22.0	8	52	1450	AA220M100F117PTR <input type="checkbox"/> <input type="checkbox"/>
	•	•	22	10	10.5	22.0	8	45	1500	AA220M100G105PTR <input type="checkbox"/> <input type="checkbox"/>
	•	•	27	10	12.4	27.0	8	40	1600	AA270M100G124PTR <input type="checkbox"/> <input type="checkbox"/>
200	•	•	33	10	12.4	33.0	8	40	1600	AA330M100G124PTR <input type="checkbox"/> <input type="checkbox"/>
	•	•	10	10	12.4	20.0	12	100	800	AA100M200G124PTR <input type="checkbox"/> <input type="checkbox"/>

: Leave **blank** for Standard package  
: Enter **W** for Vibration proof version

: Enter **X** for AEC-Q200  
: Enter **XW** for AEC-Q200 and Vibration Proof version

## MULTIPLIER $K_f$ for RIPPLE CURRENT vs. FREQUENCY

Frequency (Hz)	120 ≤ Freq. < 1k	1k ≤ Freq. < 10k	10k ≤ Freq. < 100k	100k ≤ Freq. < 300k
Coefficient $K_f$	0.1	0.3	0.6	1

**PRECAUTIONS, GUIDELINES AND PACKAGING INFORMATION**

Unless otherwise agreed in individual specifications, all products are subject to our “General Precautions and Guidelines” as well as our “Packaging Information”. Please refer to the following links in the table.

<p><a href="#">General Precautions &amp; Guidelines</a></p>	<p><a href="#">Packaging Information</a></p>	<p><a href="#">Vibration Test Profiles</a></p>	<p><a href="#">3D Models</a></p>	<p><a href="#">Reliability Tests</a></p>

**DISCLAIMER**

All product related data (e.g. specification, statements and general information) are subject to change without any notice. It is necessary that the customer observes all product related technical / application information and handling instructions.

CapXon products are designed and manufactured according to severe quality and safety standards. Under no circumstance, CapXon warrants that any CapXon product is suitable for the purposes intended for your application, even CapXon knows the application. It is customer's duty and obligation to check and make sure that CapXon products are suitable for the purposes intended and select the correct and proper CapXon product. Customers are requested to perform a sufficient validation and reliability evaluation to assure needed safety level and reliability performance by suitable designs and to apply proper safeguards (e.g. redundancies, protective circuits).

Particular operating conditions (ambient temperature, ripple current, voltage, thermal resistance, etc.) as well as storage, production or assembly may affect the performance and the lifetime of the capacitor. Please consult CapXon for lifetime estimation, failure mode considerations or worst-case scenarios according to the product technology, product tolerances / deviations or change of the characteristics of the capacitor due to shipment, storage, handling, production and usage.

For aerospace or military application, life-saving, life-sustaining, safety critical applications or any application where failure may cause severe personal injury or death, please consult us before design-in the capacitor in your application.

Except for the written expressed warranties, CapXon does not impliedly, by assumption or whatever else, warrant, undertake, promise any other warranty or guaranty for any CapXon product.



For further information, please visit our website [www.capxongroup.com](http://www.capxongroup.com) or contact CapXon directly.