

LT Series 4 Terminals Snap-in Type 85°C

Features

- ◆ Highly capacitors values and compact size.
- ◆ Two vent construction.
- ◆ 4 snap-in terminals for printed circuit board mounting.
- ◆ For detail specifications, please refer to Engineering Bulletin No. E113
- ◆ RoHS Compliant



Specifications

Item	Performance Characteristics									
Operating Temperature Range	-40 to 85 °C	-25 ~ +85°C								
Rated Voltage Range	16 ~ 100 VDC	160 ~ 450 VDC								
Capacitance Range	4700 ~ 82000 μ F	330 ~ 3300 μ F								
Capacitance Tolerance	± 20% (120Hz, +20°C)									
Leakage Current (+20°C, max.)	I ≤ 0.02 CV (μ A) After 5 minutes with rated working voltage applied.									
Dissipation Factor (tan δ , at 20°C , 120Hz)	Less than the value under table (%)									
	φ /VDC	16	25	35	50	63	80	100	160 ~ 250	350 ~ 450
	φ 35 D.F. (%) max.	45	40	35	30	25	25	20	15	20
	φ 40 D.F. (%) max.	50	45	40	35	30	25	20	15	20
Low Temperature Characteristics (at 120Hz)	Impedance ratio max.									
	Working voltage (VDC)	16	25	35 ~ 100	160 ~ 250	400 ~ 450				
	Z-25°C / Z+20°C	5	3	3	7	15				
Load Life	Test conditions									
	Duration time	:2000 Hrs								
	Ambient temperature	:+85°C								
	Applied voltage	:Rated DC working voltage								
	After test requirement at +20°C									
	Capacitance change	:≤ ±20% of the initial measured value								
	Dissipation factor	:≤ 175% of the initial specified value								
	Leakage current	:≤ The initial specified value								
Shelf Life	Test conditions									
	Duration time	:1000 Hrs								
	Ambient temperature	:+85°C								
	Applied voltage	:None								
	After test requirement at +20°C : Same limits as Load life.									
	Pre-treatment for measurements shall be conducted after application of DC working voltage for 30 minutes.									

Multiplier for Ripple Current vs. Frequency

CAP (μ F) \ Frequency(Hz)	50(60)	120	400	1K	10K	50K-100K
10 < CAP ≤ 100	0.8	1	1.23	1.36	1.48	1.53
100 < CAP ≤ 1000	0.8	1	1.16	1.25	1.35	1.38
1000 < CAP	0.8	1	1.11	1.17	1.25	1.28

Diagram of Dimensions:(unit:mm)

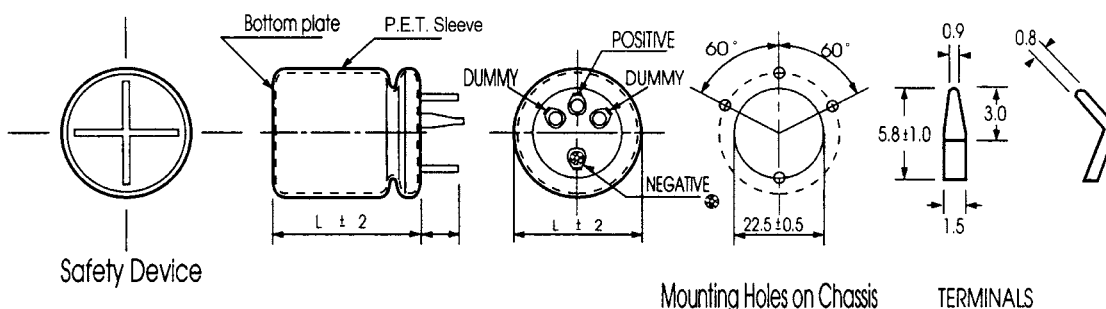

Case Size

		16				25			
Cap(μF)	WV φ D	35		40		35		40	
		Size	Ripple	Size	Ripple	Size	Ripple	Size	Ripple
33000						35x52	5.76		
39000						35x63	6.24	40x52	6.24
47000		35x32	5.88			35x83	7.08	40x63	7.08
56000		35x63	6.48	40x52	6.48			40x83	7.40
68000		35x83	7.20	40x63	7.20			40x83	8.55
82000				40x83	8.16				

		35				50			
Cap(μF)	WV φ D	35		40		35		40	
		Size	Ripple	Size	Ripple	Size	Ripple	Size	Ripple
15000						35x52	4.53		
18000						35x63	5.07	40x52	5.07
22000		35x52	4.98			35x83	5.74	40x63	5.74
27000		35x63	5.82					40x63	6.16
33000		35x83	6.00	40x63	6.38				
39000		35x83	6.91	40x63	7.00				
47000				40x83	7.52				

		63				80			
Cap(μF)	WV φ D	35		40		35		40	
		Size	Ripple	Size	Ripple	Size	Ripple	Size	Ripple
4700						35x52	3.20		
6800						35x52	3.62		
8200						35x63	3.92	40x52	3.92
10000						35x83	4.42	40x63	4.42
12000		35x63	4.65	40x52	4.80			40x83	5.10
15000		35x83	4.90	40x63	5.00			40x83	5.58
18000		35x83	5.86						
22000				40x83	6.00				

		100				160			
Cap(μF)	WV φ D	35		40		35		40	
		Size	Ripple	Size	Ripple	Size	Ripple	Size	Ripple
1800						35x52	2.46		
2200						35x63	2.77	40x52	2.77
2700						35x83	3.00	40x63	3.00
3300								40x83	3.26
5600		35x63	3.64	40x52	3.64				
6800		35x83	3.94	40x63	3.94				
8200				40x83	4.47				

		220				250			
Cap(μF)	WV φ D	35		40		35		40	
		Size	Ripple	Size	Ripple	Size	Ripple	Size	Ripple
390						35x52	1.18		
1000		35x52	2.02			35x63	2.10		
1200		35x52	2.24			35x63	2.24	40x52	2.24
1500		35x63	2.44			35x83	2.37	40x63	2.37
1800		35x83	2.65	40x63	2.65			40x83	2.79
2700				40x83	3.03				

		400				450			
Cap(μF)	WV φ D	35		40		35		40	
		Size	Ripple	Size	Ripple	Size	Ripple	Size	Ripple
330						35x52	1.16		
390						35x63	1.22		
470		35x63	1.36			35x83	1.38	40x52	1.38
560		35x83	1.44	40x52	1.44	35x83	1.50	40x63	1.50
680		35x83	1.59	40x63	1.59			40x83	1.64
820				40x83	1.78				

Ripple Current (A, rms) at 85°C 120Hz