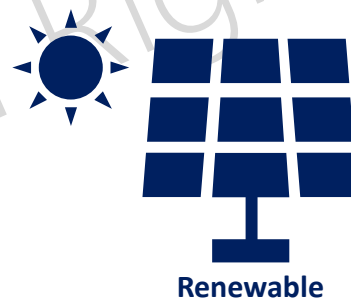
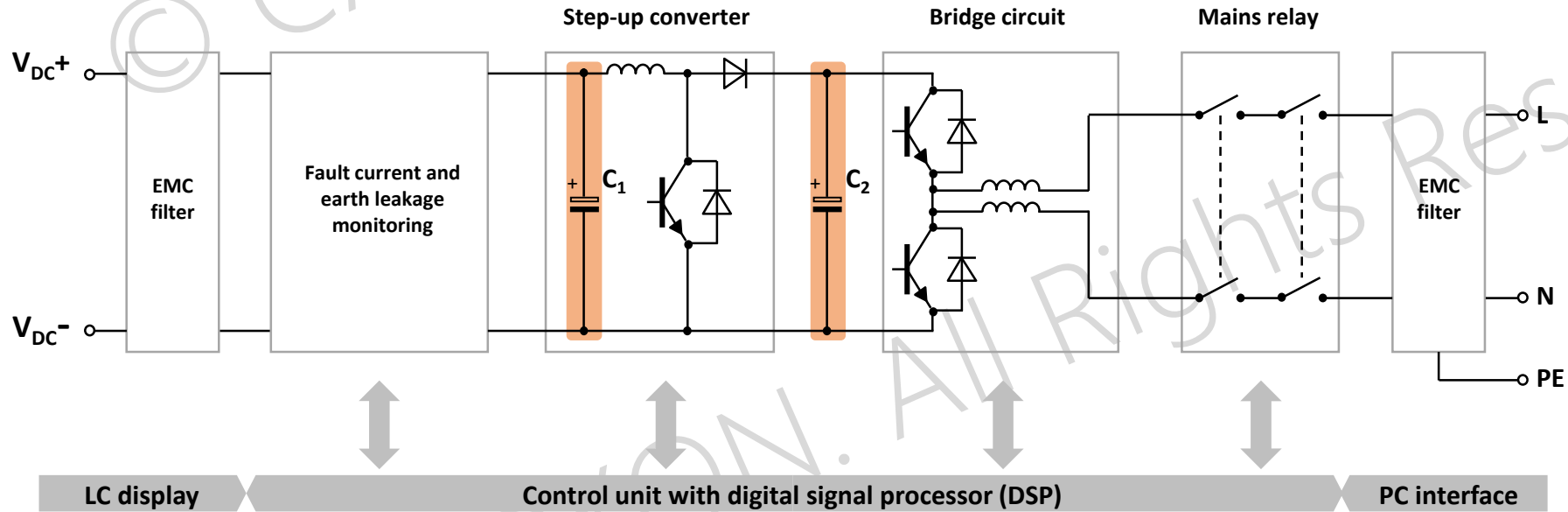

Photo Voltaic



Solar inverter - Block diagram



Solar inverter

Function	Smoothing
Request on the capacitor	High voltage
	High capacity
	High ripple current
	Long useful life
	Fixed installation mode
Recommended series	UJ, RX, UL, RH

Designator	Circuit	Purpose	Specification	Recommended series	Partnumber	Manufacturer
C1 + C2	Step-up + DC link	Smoothing	E-Cap 680 μ F, 500V, 105 $^{\circ}$ C, +/-20%, D40xL60, 3A, Snap-in	UJ	UJ681M500Q600A	CapXon
C1 + C2	Step-up + DC link	Smoothing	E-Cap 5600 μ F, 450V, 85 $^{\circ}$ C, +/-20%, D76.2xL130, 21.6A, Screw terminal	RX	RX562M450TA60A	CapXon
C1 + C2	Step-up + DC link	Smoothing	E-Cap 470 μ F, 450V, 105 $^{\circ}$ C, +/-20%, D30xL50, 2.14A, Snap-in	UL	UL471M450O500A	CapXon
C1 + C2	Step-up + DC link	Smoothing	E-Cap 1000 μ F, 350V, 105 $^{\circ}$ C, +/-20%, D51xL80, 5.7A, Screw terminal	RH	RH102M350R800A	CapXon