

PR SERIES ■ ULTRA LONG LIFE TYPE ■ 5 000 HOURS

KEY FEATURES



- **SOLID CONDUCTIVE POLYMER** ■ SMD type
- Ultra-low ESR at high frequency range
- Endurance: 105°C ■ 5 000 hours
- Large permissible ripple current
- No dry-out effect guarantees extremely long life



SPECIFICATIONS

Items		Performance Characteristics
Operating Temperature Range		-55 ~ +105°C
Rated Voltage Range	V_R	6.3 ~ 50V DC
Surge Voltage	V_S	($V_R \leq 20V$): $V_S = 1.15 \cdot V_R$ ($V_R \geq 25V$): $V_S = 1.10 \cdot V_R$
Capacitance Range	C_R	10 ~ 1500 μ F
Cap. Tolerance	ΔC	$\pm 20\%$ (120Hz ■ 20°C)
Leakage Current (20°C ■ V_R applied)	I_{LEAK}	Not to exceed the values shown in standard ratings After 2 minutes
Dissipation Factor % (20°C ■ 120Hz)	$\tan\delta$	Not to exceed the values shown in standard ratings
Equivalent Series Resistance (20°C ■ 100kHz)	ESR	Not to exceed the values shown in standard ratings

Lifetime Test		Test	5 000 hours
Endurance 105°C (V_R applied)	$\Delta C/C_R$		Within $\pm 20\%$ of the initial value
	$\tan\delta$		Not to exceed 150% of the value specified
	ESR		Not to exceed 150% of the value specified
	I_{Leak}		Less than the specified value
Moisture Resistance stored at 60°C (RH 90 ~ 95%)	$\Delta C/C_R$		Within $\pm 20\%$ of the initial value
	$\tan\delta$		Not to exceed 150% of the value specified
	ESR		Not to exceed 150% of the value specified
	I_{Leak}		Less than the specified value

DIMENSIONS STANDARD PACKAGE ■ All dimensions in mm

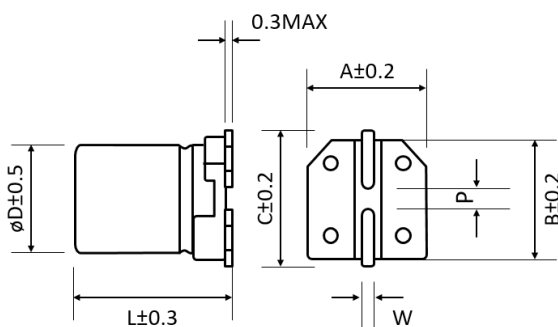

ϕD	L	A	B	C	W	P±0.2
6.3	5.8	6.5	6.5	7.2	0.5 to 0.8	2.2
6.3	7.7	6.5	6.5	7.2	0.5 to 0.8	2.2
8	7.7	8.3	8.3	9	0.7 to 1.1	3.1
8	8.7	8.3	8.3	9	0.7 to 1.1	3.1
8	10.5	8.3	8.3	9	0.7 to 1.1	3.1
8	11.7	8.3	8.3	9	0.7 to 1.1	3.1
10	10.5	10.3	10.3	11	0.7 to 1.1	4.5
10	12.4	10.3	10.3	11	0.7 to 1.1	4.5

STANDARD RATINGS

Part number shows blister tape on paper reel

V _R (V)	C _R (μF)	ø D (mm)	L (mm)	I _{LEAK} (μA, 2min)	tanδ +20°C • 120Hz (%)	Max. ESR +20°C • 100kHz (mΩ)	I _R - Max. Ripple Current +105°C • 100kHz (mA rms)	CapXon Part Number
6.3	100	6.3	5.8	300	8	32	2300	PR101M6R3E058PTR
	220	6.3	5.8	300	8	32	2300	PR221M6R3E058PTR
	220	6.3	5.8	300	8	20	2800	PR221M6R3E058PTRZ
	270	6.3	7.7	340	8	22	3000	PR271M6R3E077PTR
	470	8	7.7	592	8	22	3700	PR471M6R3F077PTR
	820	8	11.7	1033	8	12	5000	PR821M6R3F117PTR
	1000	10	10.5	1260	8	15	4700	PR102M6R3G105PTR
	1500	10	12.4	1890	8	12	5300	PR152M6R3G124PTR
10	56	6.3	5.8	300	8	32	2300	PR560M010E058PTR
	120	6.3	7.7	300	8	22	2900	PR121M010E077PTR
	150	6.3	7.7	300	8	22	2900	PR151M010E077PTR
	180	6.3	7.7	360	8	22	2900	PR181M010E077PTR
	270	8	7.7	540	8	22	3200	PR271M010F077PTR
	330	10	8.7	660	8	22	3700	PR331M010G087PTR
	470	8	11.7	940	8	12	4500	PR471M010F117PTR
	560	10	10.5	1120	8	15	4200	PR561M010G105PTR
	820	10	12.4	1640	8	12	4800	PR821M010G124PTR
	1000	10	12.4	2000	8	12	4800	PR102M010G124PTR
16	47	6.3	5.8	400	10	48	1700	PR470M016E058PTR
	82	6.3	7.7	400	10	28	2400	PR820M016E077PTR
	100	6.3	7.7	400	10	28	2400	PR101M016E077PTR
	120	6.3	7.7	400	12	28	2400	PR121M016E077PTR
	120	8	7.7	400	12	28	3000	PR121M016F077PTR
	150	8	8.7	480	12	26	3100	PR151M016F087PTR
	150	10	8.7	480	12	33	3100	PR151M016G087PTR
	180	8	11.7	576	12	18	4200	PR181M016F117PTR
	180	10	8.7	576	12	33	3100	PR181M016G087PTR
	220	8	11.7	704	12	18	4200	PR221M016F117PTR
	270	10	10.5	864	12	23	3800	PR271M016G105PTR
	330	10	10.5	1056	12	23	3800	PR331M016G105PTR
	390	10	12.4	1248	12	18	4500	PR391M016G124PTR
	560	10	12.4	1792	12	18	4500	PR561M016G124PTR
680	10	12.4	2176	12	18	4500	PR681M016G124PTR	
20	22	6.3	5.8	600	10	48	1700	PR220M020E058PTR
	33	6.3	5.8	600	10	48	1700	PR330M020E058PTR
	47	6.3	7.7	600	10	33	2300	PR470M020E077PTR
	56	6.3	7.7	600	10	33	2300	PR560M020E077PTR
	68	6.3	7.7	600	10	33	2300	PR680M020E077PTR
	82	8	7.7	600	12	33	2900	PR820M020F077PTR
	120	8	7.7	600	12	33	2900	PR121M020F077PTR
	150	8	11.7	600	12	23	4000	PR151M020F117PTR
	180	8	11.7	720	12	23	4000	PR181M020F117PTR
	180	10	10.5	720	12	25	3650	PR181M020G105PTR
	220	10	10.5	880	12	25	3650	PR221M020G105PTR
	330	10	12.4	1320	12	23	4200	PR331M020G124PTR

STANDARD RATINGS

Part number shows blister tape on paper reel

V _R (V)	C _R (μF)	ø D (mm)	L (mm)	I _{LEAK} (μA, 2min)	tanδ +20°C • 120Hz (%)	Max. ESR +20°C • 100kHz (mΩ)	I _R - Max. Ripple Current +105°C • 100kHz (mA rms)	CapXon Part Number
25	10	6.3	5.8	600	10	58	1600	PR100M025E058PTR
	22	6.3	5.8	600	10	58	1600	PR220M025E058PTR
	39	6.3	7.7	600	10	33	2300	PR390M025E077PTR
	47	6.3	7.7	600	10	33	2300	PR470M025E077PTR
	47	8	11.7	600	12	23	3700	PR470M025F117PTR
	56	8	7.7	600	12	33	2900	PR560M025F077PTR
	68	8	7.7	600	12	33	2900	PR680M025F077PTR
	68	8	11.7	600	12	23	4000	PR680M025F117PTR
	82	8	8.7	600	12	27	3200	PR820M025F087PTR
	82	8	11.7	600	12	23	4000	PR820M025F117PTR
	82	10	8.7	600	12	33	2900	PR820M025G087PTR
	100	6.3	7.7	600	12	40	2000	PR101M025E077PTR
	100	8	8.7	600	12	27	3200	PR101M025F087PTR
	120	8	11.7	600	12	23	4000	PR121M025F117PTR
	120	10	10.5	600	12	25	3650	PR121M025G105PTR
	150	10	12.4	750	12	23	4200	PR151M025G124PTR
	180	10	12.4	900	12	23	4200	PR181M025G124PTR
	220	8	11.7	1100	12	23	4000	PR221M025F117PTR
220	10	12.4	1100	12	23	4200	PR221M025G124PTR	
35	10	6.3	5.8	600	12	75	980	PR100M035E058PTR
	18	6.3	7.7	600	12	60	1400	PR180M035E077PTR
	22	8	11.7	600	12	35	2300	PR220M035F117PTR
	27	6.3	7.7	600	12	60	1400	PR270M035E077PTR
	33	8	11.7	600	12	35	2300	PR330M035F117PTR
	39	8	8.7	600	12	40	1800	PR390M035F087PTR
	56	8	11.7	600	12	35	2300	PR560M035F117PTR
	68	10	10.5	600	12	32	2500	PR680M035G105PTR
	100	10	10.5	700	12	32	2500	PR101M035G105PTR
	100	10	12.4	700	12	30	3100	PR101M035G124PTR
	150	10	10.5	700	12	32	2500	PR151M035G105PTR
	150	10	12.4	700	12	30	3100	PR151M035G124PTR
50	10	8	7.7	100	12	75	1400	PR100M050F077PTR
	12	6.3	7.7	120	12	75	1400	PR120M050E077PTR
	22	8	8.7	220	12	50	1800	PR220M050F087PTR
	22	8	11.7	220	12	40	2400	PR220M050F117PTR
	22	10	8.7	220	12	55	1800	PR220M050G087PTR
	27	8	11.7	270	12	40	2400	PR270M050F117PTR
	33	10	10.5	330	12	42	2200	PR330M050G105PTR
	33	10	12.4	330	12	30	3000	PR330M050G124PTR
	47	10	12.4	470	12	30	3000	PR470M050G124PTR
	56	10	12.4	560	12	30	3000	PR560M050G124PTR
	68	10	12.4	680	12	30	3000	PR680M050G124PTR
	100	10	12.4	1000	12	26	3650	PR101M050G124PTR

MULTIPLIER K_f for RIPPLE CURRENT vs. FREQUENCY

Frequency (Hz)	$120 \leq \text{Freq.} < 1k$	$1k \leq \text{Freq.} < 10k$	$10k \leq \text{Freq.} < 100k$	$100k \leq \text{Freq.} < 300k$
Coefficient K_f	0.05	0.3	0.7	1

PRECAUTIONS, GUIDELINES AND PACKAGING INFORMATON

Unless otherwise agreed in individual specifications, all products are subject to our “General Precautions and Guidelines” as well as our “Packaging Information”. Please refer to the following links in the table.

General Precautions & Guidelines	Packaging Information	3D Models

DISCLAIMER

All product related data (e.g. specification, statements and general information) are subject to change without any notice. It is necessary that the customer observes all product related technical / application information and handling instructions.

CapXon products are designed and manufactured according to severe quality and safety standards. Under no circumstance, CapXon warrants that any CapXon product is suitable for the purposes intended for your application, even CapXon knows the application. It is customer's duty and obligation to check and make sure that CapXon products are suitable for the purposes intended and select the correct and proper CapXon product. Customers are requested to perform a sufficient validation and reliability evaluation to assure needed safety level and reliability performance by suitable designs and to apply proper safeguards (e.g. redundancies, protective circuits).

Particular operating conditions (ambient temperature, ripple current, voltage, thermal resistance, etc.) as well as storage, production or assembly may affect the performance and the lifetime of the capacitor. Please consult CapXon for lifetime estimation, failure mode considerations or worst-case scenarios according to the product technology, product tolerances / deviations or change of the characteristics of the capacitor due to shipment, storage, handling, production and usage.

For aerospace or military application, life-saving, life-sustaining, safety critical applications or any application where failure may cause severe personal injury or death, please consult us before design-in the capacitor in your application.

Except for the written expressed warranties, CapXon does not impliedly, by assumption or whatever else, warrant, undertake, promise any other warranty or guaranty for any CapXon product.

For further information, please visit our website www.capxongroup.com or contact CapXon directly.