

### JV SERIES ■ LONG LIFE, AUTOMOTIVE 105°C TYPE

#### KEY FEATURES



- ALUMINUM ELECTROLYTIC CAPACITOR ■ SMD type
- Endurance: 105°C ■ 3 000 hours
- Small dimensions
- Vibration-proof (VP) version (up to 30g) available upon request
- AEC-Q200 version available



#### SPECIFICATIONS

Items		Performance Characteristics						
Operating Temperature Range		-55 ~ +105°C						
Rated Voltage Range	$V_R$	6.3 ~ 50V DC						
Surge Voltage	$V_S$	$V_S = 1.15 \cdot V_R$						
Capacitance Range	$C_R$	0.1 ~ 1000 $\mu$ F						
Cap. Tolerance	$\Delta C$	$\pm 20\%$ (120Hz ■ 20°C)						
Leakage Current (20°C ■ $V_R$ applied)	$I_{LEAK}$	$\leq 0.01 \cdot C_R \cdot V_R$ or 3 $\mu$ A, whichever is greater ■ After 2 minutes [ $I_{LEAK}$ ( $\mu$ A) ; $C_R$ ( $\mu$ F) ; $V_R$ (V) ]						
Dissipation Factor % (20°C ■ 120Hz)	$\tan \delta$	$V_R$ (V DC)	6.3	10	16	25	35	50
		$\tan \delta$	28	24	20	16	13	12
Low Temperature Characteristics at 120Hz	Z ratio max.	$V_R$ (V DC)	6.3	10	16	25	35	50
		Z-25°C/Z+20°C	4	3	2	2	2	2
		Z-40°C/Z+20°C	10	7	5	3	3	3
		Z-55°C/Z+20°C	12	10	6	5	4	4
Lifetime Test								
Endurance 105°C ( $V_R$ applied)	Test	<b>3 000 hours</b>						
	$\Delta C/C_R$	$\leq \pm 30\%$ of initial measured value						
	$\tan \delta$	$\leq 300\%$ of initial specified value						
	$I_{Leak}$	$\leq$ the initial specified value						
Shelf Life 105°C ( $V_R = 0$ )	Test	<b>1 000 hours</b>						
	$\Delta C/C_R$	$\leq \pm 30\%$ of initial measured value						
	$\tan \delta$	$\leq 300\%$ of initial specified value						
	$I_{Leak}$	$\leq$ the initial specified value						
		Before measurement: Restore capacitor to 20°C, apply $V_R$ for 30 min according JIS-C-5101-4						
Resistance to Soldering Heat	The capacitors shall be kept on a hot plate maintained at 250°C for 30 seconds. After removing from the hot plate and restored at room temperature, they meet the characteristic requirements listed below							
	$\Delta C/C_R$	Within $\pm 10\%$ of initial value						
	$\tan \delta$	Less than specified value						
	$I_{Leak}$	Less than specified value						

**STANDARD RATINGS**

Part number shows blister tape on paper reel

V <sub>R</sub> (V)	Standard	Vibration-proof	C <sub>R</sub> (μF)	ø D (mm)	L (mm)	I <sub>R</sub> - Max. Ripple Current +105°C - 120Hz (mA rms)	CapXon Part Number
6.3	•		22	4	5.5	22	JV220M6R3B055ETR □□
	•		33	5	5.5	33	JV330M6R3C055ETR □□
	•		47	5	5.5	36	JV470M6R3C055ETR □□
	•		100	6.3	5.5	68	JV101M6R3E055ETR □□
	•	•	220	6.3	7.7	120	JV221M6R3E077ETR □□
	•	•	330	8	10.5	230	JV331M6R3F105ETR □□
	•	•	470	10	10.5	290	JV471M6R3G105ETR □□
	•	•	1000	10	10.5	360	JV102M6R3G105ETR □□
10	•		22	5	5.5	30	JV220M010C055ETR □□
	•		33	5	5.5	35	JV330M010C055ETR □□
	•		47	6.3	5.5	52	JV470M010E055ETR □□
	•	•	100	6.3	7.7	81	JV101M010E077ETR □□
	•	•	220	8	10.5	142	JV221M010F105ETR □□
	•	•	330	10	10.5	280	JV331M010G105ETR □□
	•		470	10	10.5	305	JV471M010G105ETR □□
	•		10	4	5.5	18	JV100M016B055ETR □□
16	•		22	5	5.5	31	JV220M016C055ETR □□
	•		33	6.3	5.5	48	JV330M016E055ETR □□
	•		47	6.3	5.5	51	JV470M016E055ETR □□
	•	•	100	6.3	7.7	83	JV101M016E077ETR □□
	•	•	220	10	10.5	222	JV221M016G105ETR □□
	•	•	330	10	10.5	305	JV331M016G105ETR □□
	•	•	470	10	10.5	330	JV471M016G105ETR □□
	•		4.7	4	5.5	16	JV4R7M025B055ETR □□
25	•		10	4	5.5	26	JV100M025B055ETR □□
	•		22	6.3	5.5	44	JV220M025E055ETR □□
	•		33	6.3	5.5	50	JV330M025E055ETR □□
	•	•	47	6.3	7.7	66	JV470M025E077ETR □□
	•	•	100	8	10.5	118	JV101M025F105ETR □□
	•	•	220	10	10.5	300	JV221M025G105ETR □□
	•	•	330	10	10.5	395	JV331M025G105ETR □□
	•	•	470	10	10.5	470	JV471M025G105ETR □□
35	•		4.7	4	5.5	16	JV4R7M035B055ETR □□
	•		10	5	5.5	27	JV100M035C055ETR □□
	•		22	6.3	5.5	45	JV220M035E055ETR □□
	•	•	33	6.3	7.7	58	JV330M035E077ETR □□
	•	•	47	8	10.5	93	JV470M035F105ETR □□
	•	•	100	10	10.5	155	JV101M035G105ETR □□
	•	•	220	10	10.5	340	JV221M035G105ETR □□
	•	•	330	10	10.5	420	JV331M035G105ETR □□

□□ see description at end of standard ratings

### STANDARD RATINGS

Part number shows blister tape on paper reel

$V_R$ (V)	Standard	$C_R$ ( $\mu F$ )	$\phi D$ (mm)	L (mm)	$I_R$ - Max. Ripple Current +105°C - 120Hz (mA rms)	CapXon Part Number
	Vibration-proof					
50	•	0.1	4	5.5	1	JV0R1M050B055ETR □□
	•	0.22	4	5.5	2.6	JVR22M050B055ETR □□
	•	0.33	4	5.5	3.2	JVR33M050B055ETR □□
	•	0.47	4	5.5	5	JVR47M050B055ETR □□
	•	1	4	5.5	8	JV010M050B055ETR □□
	•	2.2	4	5.5	12	JV2R2M050B055ETR □□
	•	3.3	4	5.5	17	JV3R3M050B055ETR □□
	•	4.7	5	5.5	22	JV4R7M050C055ETR □□
	•	10	6.3	5.5	33	JV100M050E055ETR □□
	•	22	6.3	7.7	58	JV220M050E077ETR □□
	•	33	8	10.5	140	JV330M050F105ETR □□
	•	47	8	10.5	170	JV470M050F105ETR □□
	•	100	10	10.5	300	JV101M050G105ETR □□

□□: Enter **blank** for Standard package  
 □□: Enter **W** for Vibration proof version

□□: Enter **X** for AEC-Q200  
 □□: Enter **XW** for AEC-Q200 and Vibration proof version

### DIMENSIONS STANDARD PACKAGE - All dimensions in mm

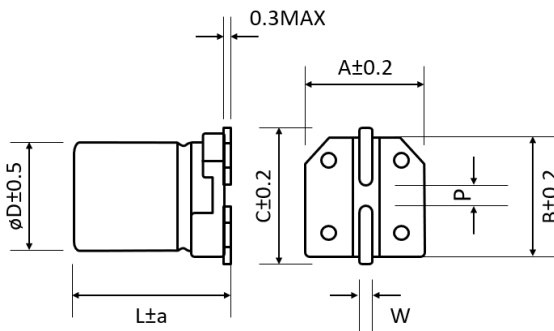

$\phi D$	L	a	A	B	C	W	P $\pm 0.2$
4	5.5	Max	4.3	4.3	4.9	0.5 to 0.8	1
5	5.5	Max	5.3	5.3	5.9	0.5 to 0.8	1.4
6.3	5.5	0.2	6.6	6.6	7.2	0.5 to 0.8	2.2
6.3	7.7	Max	6.6	6.6	7.2	0.5 to 0.8	2.2
8	10.5	Max	8.3	8.3	9	0.7 to 1.1	3.1
10	10.5	Max	10.3	10.3	11	0.7 to 1.1	4.5

### DIMENSIONS VP PACKAGE (VIBRATION-PROOF) - All dimensions in mm

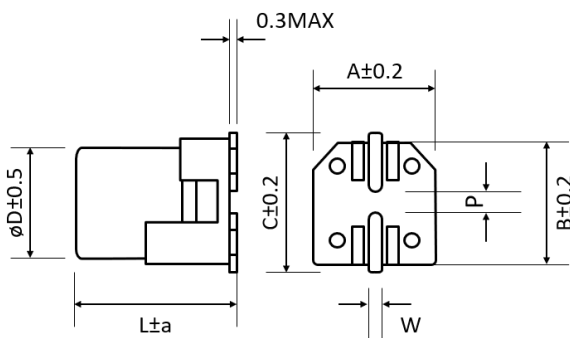

$\phi D$	L	a	A	B	C	W	P $\pm 0.2$
6.3	7.7	0.5	6.6	6.6	7.2	0.5 to 0.8	2.2
8	10.5	0.5	8.3	8.3	9	0.7 to 1.1	3.1
10	10.5	0.5	10.5	10.5	11.2	0.7 to 1.1	4.5

## MULTIPLIER $K_f$ for RIPPLE CURRENT vs. FREQUENCY

$C_R$ ( $\mu$ F) / Frequency (Hz)	50/60	100/120	500	1k	$\geq 10k$
$0.1 \leq C_R \leq 100$	0.8	1	1.2	1.3	1.5
$100 < C_R \leq 1000$	0.8	1	1.1	1.15	1.2

## PRECAUTIONS, GUIDELINES AND PACKAGING INFORMATION

Unless otherwise agreed in individual specifications, all products are subject to our “General Precautions and Guidelines” as well as our “Packaging Information”. Please refer to the following links in the table.

<a href="#">General Precautions &amp; Guidelines</a>	<a href="#">Packaging Information</a>	<a href="#">Vibration Test Profiles</a>	<a href="#">3D Models</a>

### DISCLAIMER

All product related data (e.g. specification, statements and general information) are subject to change without any notice. It is necessary that the customer observes all product related technical / application information and handling instructions.

CapXon products are designed and manufactured according to severe quality and safety standards. Under no circumstance, CapXon warrants that any CapXon product is suitable for the purposes intended for your application, even CapXon knows the application. It is customer's duty and obligation to check and make sure that CapXon products are suitable for the purposes intended and select the correct and proper CapXon product. Customers are requested to perform a sufficient validation and reliability evaluation to assure needed safety level and reliability performance by suitable designs and to apply proper safeguards (e.g. redundancies, protective circuits).

Particular operating conditions (ambient temperature, ripple current, voltage, thermal resistance, etc.) as well as storage, production or assembly may affect the performance and the lifetime of the capacitor. Please consult CapXon for lifetime estimation, failure mode considerations or worst-case scenarios according to the product technology, product tolerances / deviations or change of the characteristics of the capacitor due to shipment, storage, handling, production and usage.

For aerospace or military application, life-saving, life-sustaining, safety critical applications or any application where failure may cause severe personal injury or death, please consult us before design-in the capacitor in your application.

Except for the written expressed warranties, CapXon does not impliedly, by assumption or whatever else, warrant, undertake, promise any other warranty or guaranty for any CapXon product.

For further information, please visit our website [www.capxongroup.com](http://www.capxongroup.com) or contact CapXon directly.