

HH SERIES ▪ HIGH VOLTAGE, AUTOMOTIVE 125°C TYPE

KEY FEATURES

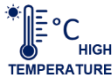

- **HIGH TEMPERATURE** ▪ Snap-In type
- Useful life: 125°C ▪ 4000 hours
- High reliability and high voltage applications
- Extremely stable dissipation factor and leakage current
- AEC-Q200 version available



SPECIFICATIONS

Items		Performance Characteristics	
Operating Temperature Range		-40 ~ +125°C	
Rated Voltage Range	V_R	400 ~ 450V DC	
Surge Voltage	V_S	$V_S = 1.10 \cdot V_R$	
Capacitance Range	C_R	47 ~ 560μF	
Cap. Tolerance	ΔC	±20% (120Hz ▪ 20°C)	
Leakage Current (20°C ▪ V_R applied)	I_{LEAK}	$\leq 0.02 \cdot C_R \cdot V_R$ ▪ After 5 minutes [I_{LEAK} (μA) ; C_R (μF) ; V_R (V)]	
Dissipation Factor % (20°C ▪ 120Hz)	$\tan\delta$	Not to exceed the values shown in standard ratings	
Series-Resistance (20°C ▪ 120Hz)	ESR	Not to exceed the values shown in standard ratings	
Low Temperature Characteristics at 120Hz	Z ratio max.	V_R (V DC)	400 450
		Z-25°C/Z+20°C	6 6
		Z-40°C/Z+20°C	10 10

Lifetime Test			
Useful Life 125°C (V_R & I_R applied)	Test	4000 hours	
	$\Delta C/C_R$	$\leq \pm 30\%$ of initial measured value	
	$\tan\delta$	$\leq 300\%$ of initial specified value	
	I_{Leak}	\leq the initial specified value	
	Deviation Rate @ Useful Life: 10 000 FIT = 1%/1000h with 60% confidence level ▪ parts show higher drift as test criteria		
Endurance 125°C (V_R & I_R applied)	Test	3000 hours	
	$\Delta C/C_R$	$\leq \pm 20\%$ of initial measured value	
	$\tan\delta$	$\leq 200\%$ of initial specified value	
	I_{Leak}	\leq the initial specified value	
Shelf Life 125°C ($V_R = 0$)	Test	1000 hours	
	$\Delta C/C_R$	$\leq \pm 20\%$ of initial measured value	
	$\tan\delta$	$\leq 200\%$ of initial specified value	
	I_{Leak}	\leq the initial specified value	
Before measurement: Restore capacitor to 20°C, apply V_R for 30 min according JIS-C-5101-4			
Vibration Resistance Test	Max. 10g force, f_{RANGE} 10Hz ... 55Hz, amplitude 0.75mm; X/Y/Z-axis each 2h; capacitor rigidly clamped by body to surface ▪ IEC 60068-2-6		

STANDARD RATINGS

V_R (V)	C_R (μ F)	ϕD (mm)	L (mm)	I_{LEAK} (μ A, 5min)	$\tan\delta$ +20°C • 120Hz (%)	Max. ESR +20°C • 120Hz (m Ω)	I_r • Max. Ripple Current +125°C • 120Hz (mA rms)	CapXon Part Number
400	47	22	25	376	20	4230	260	HH470M400M250A□□□
	68	22	30	544	20	2930	340	HH680M400M300A□□□
	82	22	30	656	20	2430	380	HH820M400M300A□□□
	100	22	35	800	20	1990	430	HH101M400M350A□□□
	120	22	35	960	20	1660	500	HH121M400M350A□□□
	150	22	40	1200	20	1330	550	HH151M400M400A□□□
	180	22	45	1440	20	1110	640	HH181M400M450A□□□
	220	25	45	1760	20	900	780	HH221M400N450A□□□
	270	25	50	2160	20	740	920	HH271M400N500A□□□
	330	30	45	2640	20	600	1020	HH331M400O450A□□□
	390	30	50	3120	20	510	1160	HH391M400O500A□□□
	470	35	45	3760	20	420	1340	HH471M400P450A□□□
560	35	50	4480	20	360	1560	HH561M400P500A□□□	
450	68	22	30	612	20	2930	380	HH680M450M300A□□□
	82	22	35	738	20	2430	440	HH820M450M350A□□□
	100	22	40	900	20	1990	460	HH101M450M400A□□□
	120	22	45	1080	20	1660	540	HH121M450M450A□□□
	150	22	50	1350	20	1330	620	HH151M450M500A□□□
	180	22	55	1620	20	1110	730	HH181M450M550A□□□
	220	25	50	1980	20	900	870	HH221M450N500A□□□
	270	30	45	2430	20	740	1120	HH271M450O450A□□□
	330	30	50	2970	20	600	1300	HH331M450O500A□□□
	390	35	45	3510	20	510	1480	HH391M450P450A□□□
	470	35	50	4230	20	420	1670	HH471M450P500A□□□

□□□: Enter **P6** for standard type • 6mm pin length
 □□□: Enter **P6X** for standard type • 6mm pin length • AEC-Q200
 □□□: Enter **Z6** for 3-pin type • 6mm pin length
 □□□: Enter **Z6X** for 3-pin type • 6mm pin length • AEC-Q200
 □□□: Enter **Y6** for multi-pin type • 6mm pin length
 □□□: Enter **Y6X** for multi-pin type • 6mm pin length • AEC-Q200

□□□: Enter **P4** for standard type • 4mm pin length
 □□□: Enter **P4X** for standard type • 4mm pin length • AEC-Q200
 □□□: Enter **Z4** for 3-pin type • 4mm pin length
 □□□: Enter **Z4X** for 3-pin type • 4mm pin length • AEC-Q200
 □□□: Enter **Y4** for multi-pin type • 4mm pin length
 □□□: Enter **Y4X** for multi-pin type • 4mm pin length • AEC-Q200

DIMENSIONS • All dimensions in mm

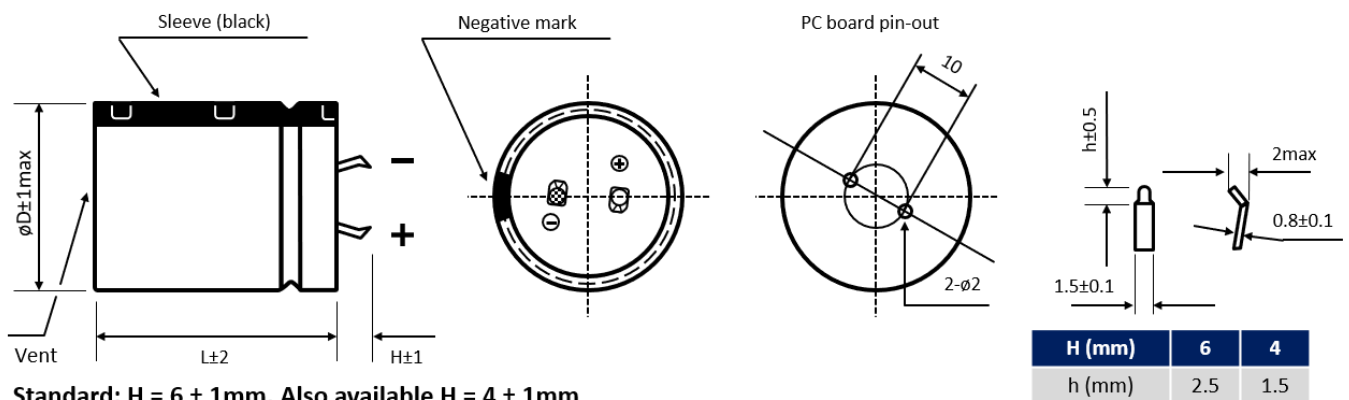
 2-pin version • Diameter ϕD 20 mm to 25 mm • Standard type

DIMENSIONS ▪ All dimensions in mm

3-pin version ▪ Polarity protection ▪ Diameter ϕ D 20 mm to 25 mm

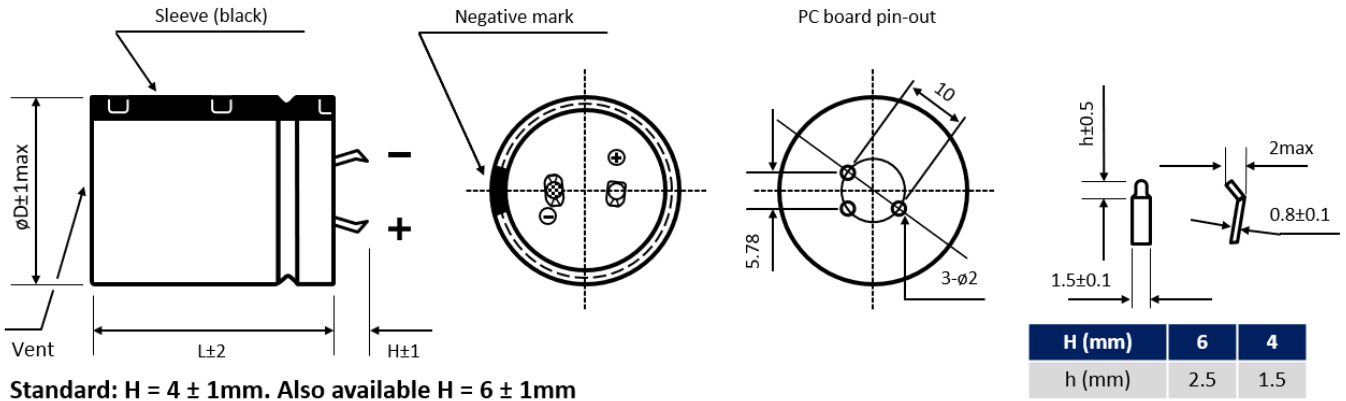

Standard: H = 4 ± 1mm. Also available H = 6 ± 1mm

Multipin version ▪ Diameter ϕ D ≥ 30 mm

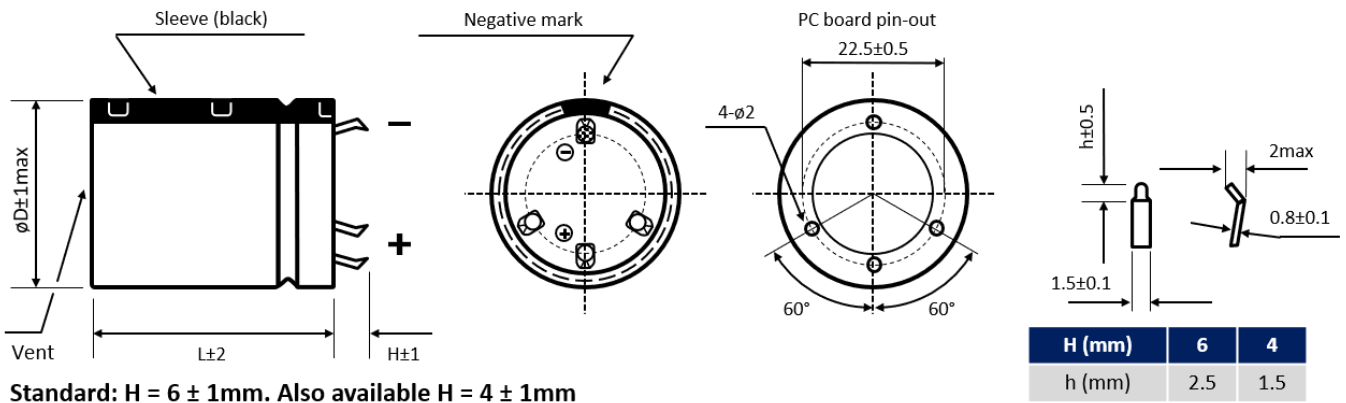

Standard: H = 6 ± 1mm. Also available H = 4 ± 1mm

Further possible terminal styles can be found in our packaging information liquid snap-in.

MULTIPLIER K_f for RIPPLE CURRENT vs. FREQUENCY

V_R (V) / Frequency (Hz)	50/60	100/120	300	1k	10k	50k
$400 \leq V_R \leq 450$	0.77	1	1.16	1.3	1.41	1.43

PRECAUTIONS, GUIDELINES AND PACKAGING INFORMATION

Unless otherwise agreed in individual specifications, all products are subject to our “General Precautions and Guidelines” as well as our “Packaging Information”. Please refer to the following links in the table.

General Precautions & Guidelines	Packaging Information	Vibration Test Profiles	3D Models



DISCLAIMER

All product related data (e.g. specification, statements and general information) are subject to change without any notice. It is necessary that the customer observes all product related technical / application information and handling instructions.

CapXon products are designed and manufactured according to severe quality and safety standards. Under no circumstance, CapXon warrants that any CapXon product is suitable for the purposes intended for your application, even CapXon knows the application. It is customer's duty and obligation to check and make sure that CapXon products are suitable for the purposes intended and select the correct and proper CapXon product. Customers are requested to perform a sufficient validation and reliability evaluation to assure needed safety level and reliability performance by suitable designs and to apply proper safeguards (e.g. redundancies, protective circuits).

Particular operating conditions (ambient temperature, ripple current, voltage, thermal resistance, etc.) as well as storage, production or assembly may affect the performance and the lifetime of the capacitor. Please consult CapXon for lifetime estimation, failure mode considerations or worst-case scenarios according to the product technology, product tolerances / deviations or change of the characteristics of the capacitor due to shipment, storage, handling, production and usage.

For aerospace or military application, life-saving, life-sustaining, safety critical applications or any application where failure may cause severe personal injury or death, please consult us before design-in the capacitor in your application.

Except for the written expressed warranties, CapXon does not impliedly, by assumption or whatever else, warrant, undertake, promise any other warranty or guaranty for any CapXon product.

For further information, please visit our website www.capxongroup.com or contact CapXon directly.